

ROHS Compliant

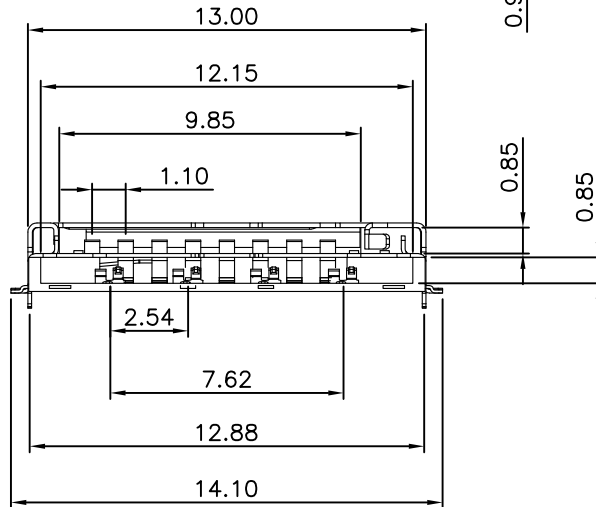
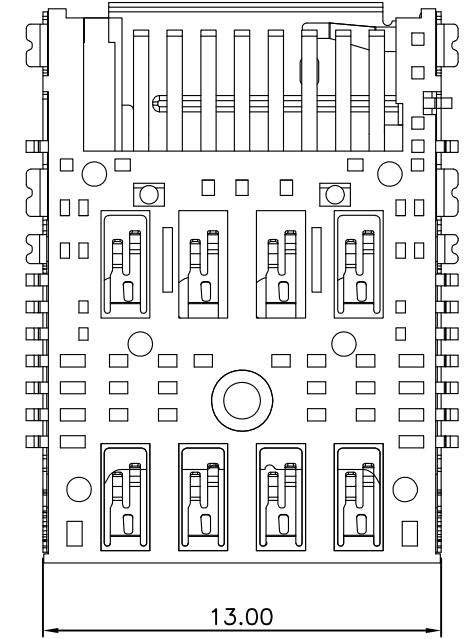
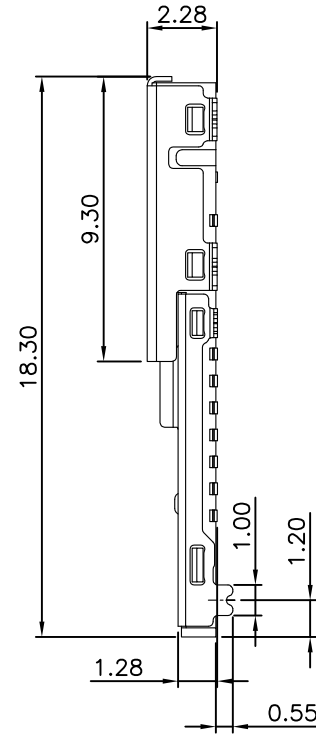
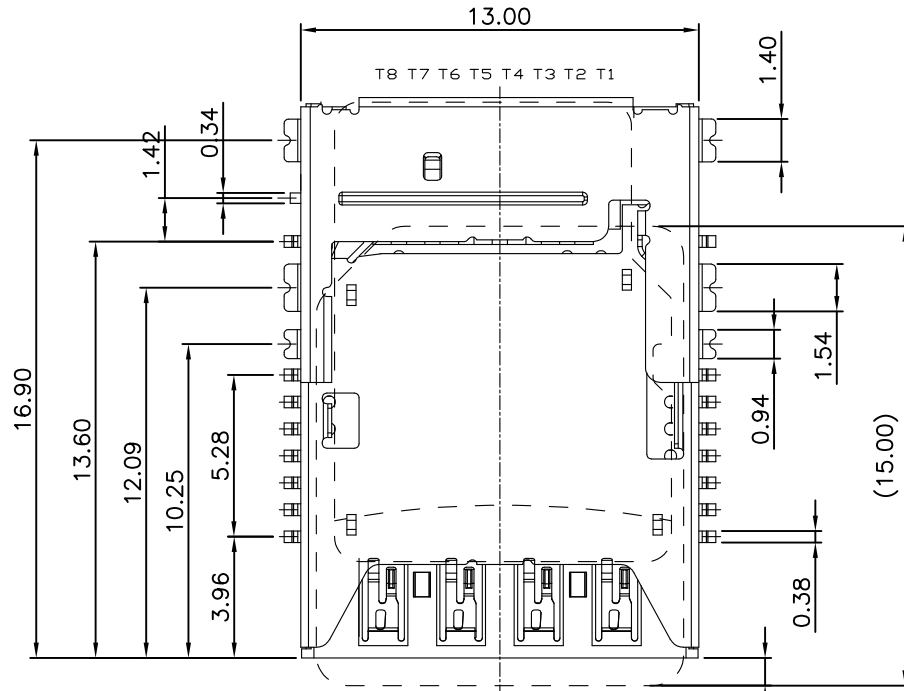

REV.	ECN NO OR DESCRIPTION	REVISED	DATE
A	PRODUCT RELEASE	JAMES	2008.03.29
B	MODIFY	JAMES	2018.08.16

NO	DESCRIPTION	QTY	MATERIAL	PLATING & COLOR
D	SHELL-B	1	STAINLESS STEEL 0.10t	Ni PLATING
C	SHELL-A	1	STAINLESS STEEL 0.10t	Ni PLATING
B	CONTACT	17	COPPER ALLOY 0.10t	Gold Flash On Contact Area Tin plated on Solder tail All over Nickel Plated .
A	HOUSING	1	HIGH-TEMPERATURE PLASTIC UL94-V0	BLACK

UNLESS OTHERWISE SPECIFIED TOLERANCES

DECIMALS: ANGLES:
 X :±0.5 X :±2°
 X.X :±0.3 X.X :±1°
 X.XX :±0.2



TITLE:		
MICRO SIM +TF CARD二合一帶偵測pin		
PART NO.	1051401AR002	
DWN	JAMES	2018.08.16
CHKD		
APVD		
SCALE 1:1	UNIT: mm	

CUSTOMER COPY	SIZE: A4	SHEET: 10F2	REV: B
---------------	----------	-------------	--------

ROHS Compliant

REV.	ECN NO OR DESCRIPTION	REVISED	DATE
A	PRODUCT RELEASE	JAMES	2008.03.29
B	MODIFY	JAMES	2018.08.16

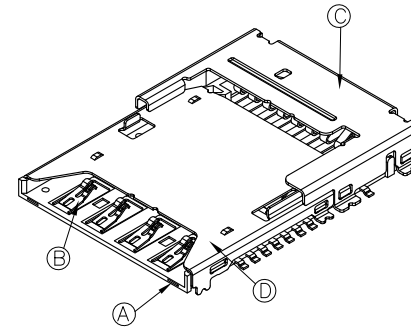
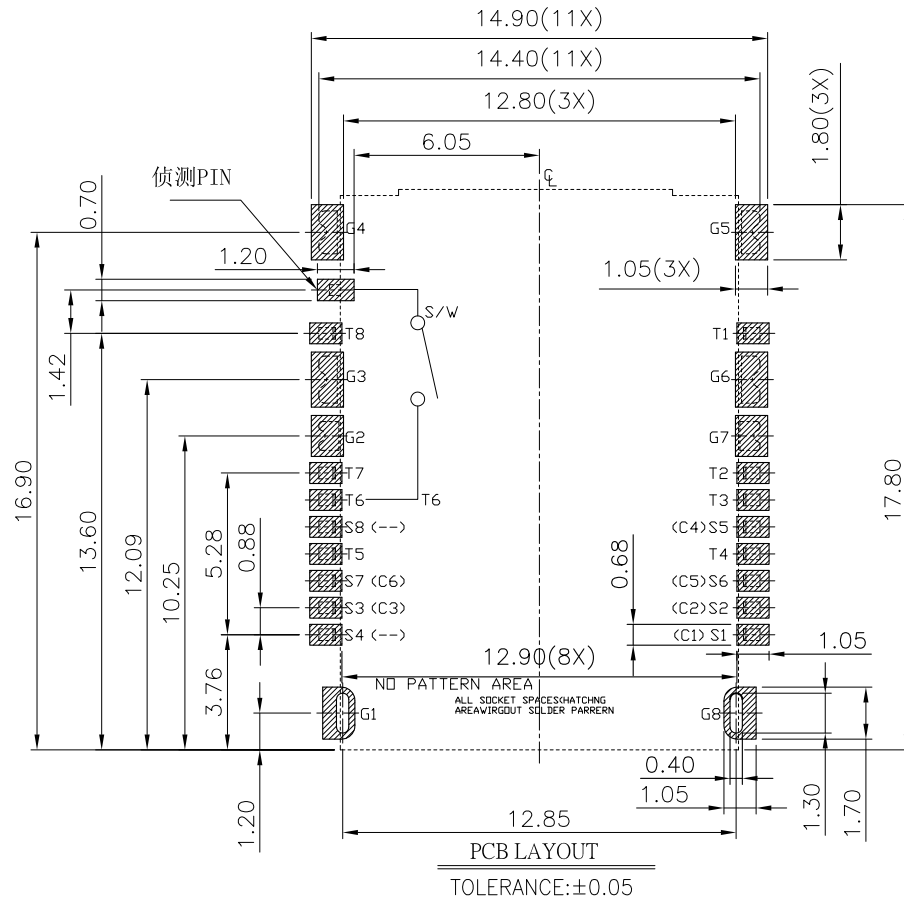

SPECIFICATIONS :

- ELECTRICAL CHARACTERISTICS
 - CONTACT RESISTANCE: 80 milliohms MAX.
 - INSULATION RESISTANCE: 1,000 Megohms MIN.
 - DIELECTRIC WITHSTANDING VOLTAGE: 500V AC FOR 1 MINUTE.
- MECHANICAL CHARACTERISTICS
 - INSERTION FORCE: 1kgf MAX
 - WITHDRAW FORCE: 0.1kgf MIN
 - DURABILITY: 5000 CYCLES
- RoHS 2002/95/EC COMPLIANT.

MICRO SIM CARD PIN-MAP

8P	6P	DESCRIPTION
S1	C1	VCC(Supply V)
S2	C2	RST(Reset)
S3	C3	CLK(Clock)
S4	--	Reserved
S5	C4	GND
S6	C5	Vpp(Program V)
S7	C6	I/O
S8	--	Reserved
G1~G8		GND

MICRO SD CARD PIN-MAP

PIN NO.	DESCRIPTION
T1	DAT2
T2	CD/DAT3 ²
T3	CMD
T4	VDD
T5	CLK
T6	Vss(GND)
T7	DAT0
T8	DAT1

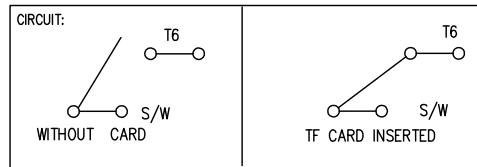

NO	DESCRIPTION	QTY	MATERIAL	PLATING & COLOR
D	SHELL-B	1	STAINLESS STEEL 0.10t	Ni PLATING
C	SHELL-A	1	STAINLESS STEEL 0.10t	Ni PLATING
B	CONTACT	17	COPPER ALLOY 0.10t	Gold Flash On Contact Area Tin plated on Solder tail All over Nickel Plated
A	HOUSING	1	HIGH-TEMPERATURE PLASTIC UL94-V0	BLACK

UNLESS OTHERWISE SPECIFIED TOLERANCES

DECIMALS: ANGLES:
 X :±0.5 X :±2°
 X.X :±0.3 X.X :±1°
 X.XX :±0.2



TITLE:			
MICRO SIM +TF CARD二合一带侦测pin			
PART NO.	1051401A002		
DWN	JAMES	2018.08.16	
CHKD			
APVD			
SCALE 1:1	UNIT: mm	⊕	
CUSTOMER COPY	SIZE: A4	SHEET: 20F2	REV: B